



CITY OF BRUNSWICK, GEORGIA
APPLICATION FOR CERTIFICATE OF APPROPRIATENESS
& MATERIAL CHANGES TO EXTERIOR FEATURES
 Brunswick Historic Preservation Board

COA

1. Name of Applicant: JOSE A. GUTIERREZ Date: _____

You or your representative must be present at the meeting of the Board to answer questions that may arise. You will be notified of the time, date, and location of the meeting.

Mailing Address: 617 ELLIS ST ; BRUNSWICK, GA Zip Code: 31520

Daytime Telephone: 504-606-8152

E-mail Address: JOEGUTIERREZ@YMAIL.COM

Relationship of Applicant to Property: Owner () Architect () Contractor
 () Other (Specify) _____

2. Address and Legal Description of Property: _____

Year Built: 1890 Historic Designation: () Historic (more than 50 years old and contributing)
 Era: _____ () Historic-obscured (50 years old but not contributing)
 () Non-historic (less than 50 years old, yet not detracting)
 () Intrusions (any aged structure, which detracts)
 () Vacant

3. Proposed Work:

- () New Construction () New Signage
- () Demolition () Parking Lot, Driveway or Walkway
- () Relocation () Outbuilding or Accessory Structure
- () Excavation () Lighting Fixtures
- () Fencing or landscaping () Other
- () Reconstruction or alteration of the size, shape or façade of an existing structure.
- () A change in the location or extent of signage.

Please describe your proposed work as simply and accurately as possible. Be sure to indicate materials to be used, it is recommended you provide material samples. Accurate to-scale drawings and photographs required are to be attached. A location map is required to be attached to this application.

IMPORTANT: This form must be completed before the Brunswick Historic Preservation Board can consider approval of any change affecting the appearance of any building, or property within the Historic District. This form, along with supporting documents, must be filed with the Historic Preservation Officer, 601 Gloucester Street at least 15 days prior to the regularly scheduled Board meeting. The Historic Preservation Board meets the first Monday of each month at 6:00 PM in at Old City Hall, 1229 Newcastle St. unless otherwise advertised.



CITY OF BRUNSWICK, GEORGIA
**APPLICATION FOR CERTIFICATE OF APPROPRIATENESS
& MATERIAL CHANGES TO EXTERIOR FEATURES**
Brunswick Historic Preservation Board

C₂

All applicable items from the attached checklist must be addressed. Incomplete applications will not be accepted or docketed for consideration by the Historic Preservation Board.

For additional help of information, contact the Historic Preservation Officer at (912) 267-5527

SIGNATURE OF APPLICANT:

Staff Comments: _____

**CITY OF BRUNSWICK
CERTIFICATE OF APPROPRIATENESS
Brunswick Historic Preservation Board**

A Certificate of Appropriateness is hereby issued to: _____

For the following actions: _____

at _____

provided the following conditions are met: _____

SIGNATURE:

Chairperson, Historic Preservation Board

DATE: _____

617 ELLIS ST - 31520

COLUMN COVERS

WOOD-STAINED OR PAINTED
THICKNESS OF WOOD CAN BE CHANGED

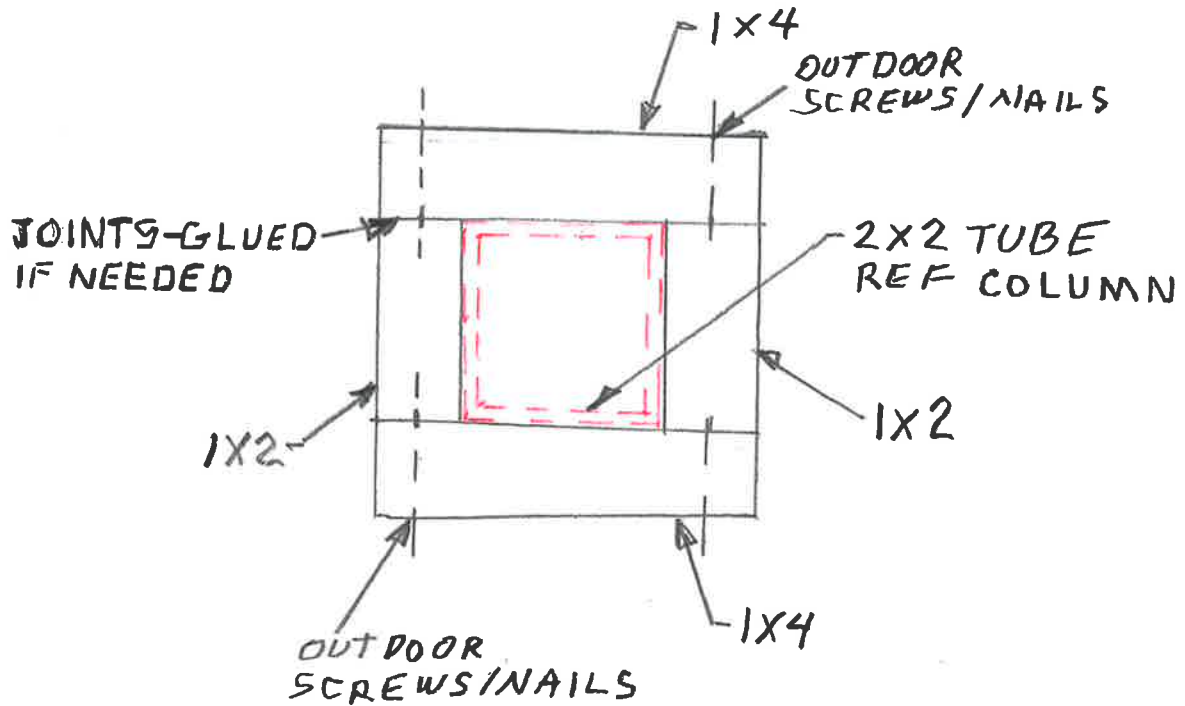

617 ELLIS ST
31250

FENCE ~ BACKYARD ~

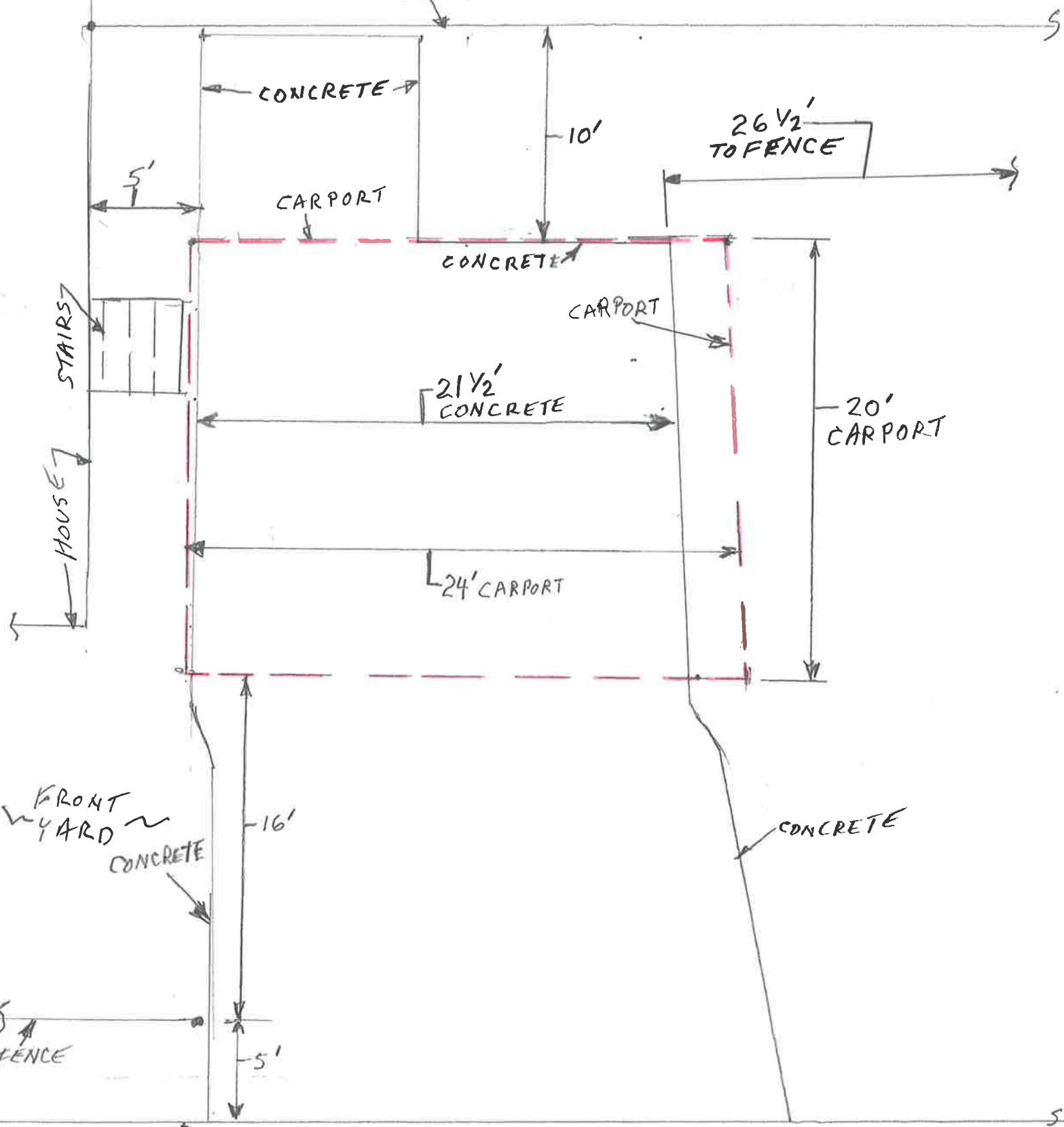

STREET

tor.com



Public Owner

CONCRETE WIDTH
21 1/2'

HOUSE TO
CONCRETE
5'

12' TO FENCE

WIDTH OF
CARPORT 24'

20' LENGTH
CARPORT

16' END OF CARPORT
TO END OF FENCE

5'

STREET

617 ELLIS ST.
31250



Front End Right Side Back End Left Side

Metal Buildings

3D Builder

More

Contact/FAQ

My Account (/mv-

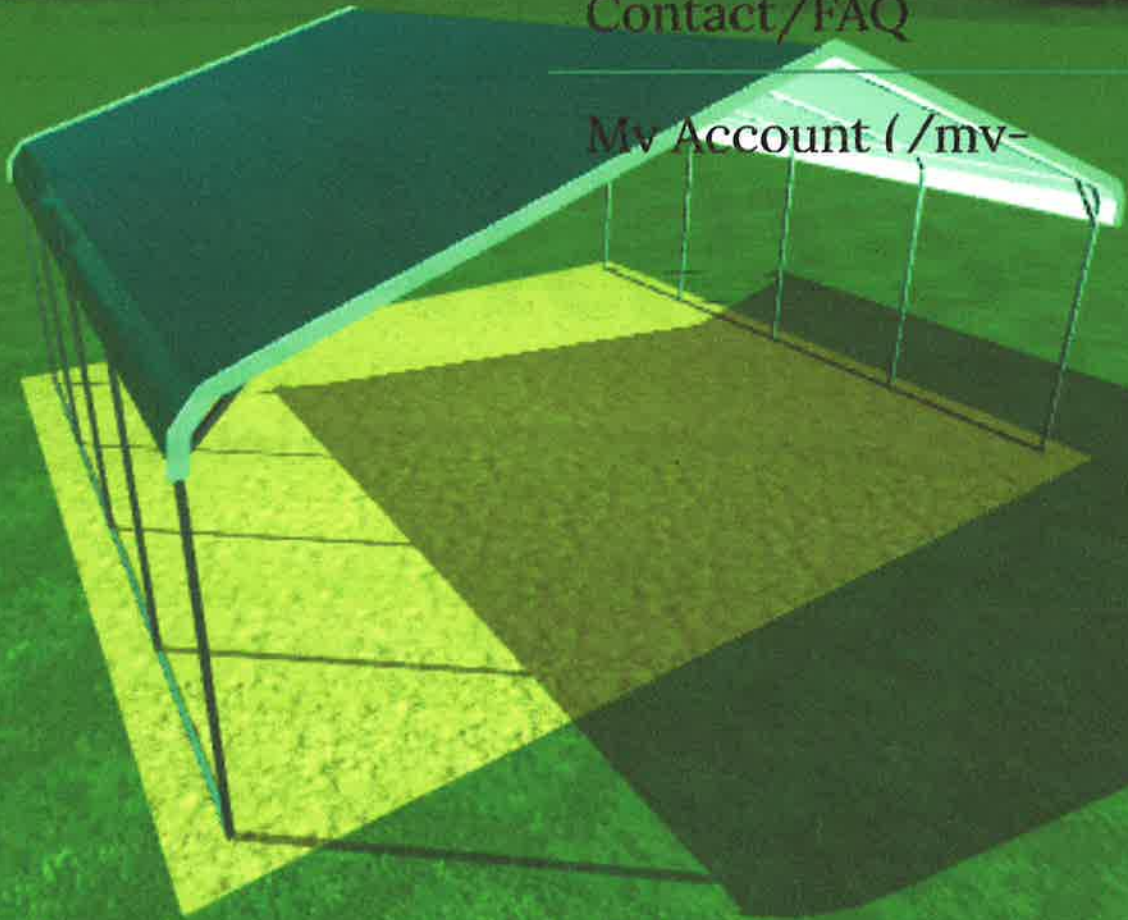

Copyright © 2022 Alans Factory Outlet. All Rights Reserved

Hide Custom Product Summary ▲